

Linear Electric Actuator

Series AELS

Cat :

Rodless Type Ball Screw Actuator - 120mm

Features

- Compact Robust Design
- Highly flexible mounting
- More Precise & positioning
- Ease of positioning
- Ease of Maintenance



Technical Specifications

Repeatability (mm)		±0.01			
Motor Power (AC Servo in W)		400			
Ball Screw Lead (mm)		5	10	20	32
Maximum Speed (mm/s)*		250	500	1000	1600
Maximum Payload	Horizontal (Kg)	110	88	40	30
	Vertical (Kg)	33	22	10	8
Rated Thrust (N)		1388	694	347	218
Stroke / Pitch (mm)**		50-1250mm / 50 mm Pitch			
Ball Screw Ø (mm)		C7 Ø 16			
Coupling (mm)		10x14			
Home Sensor	Outside	EE-SX674 (NPN)			

* Acceleration and deceleration value is set 0.2 second

** When the stroke is over 800mm the run-out of the ball screw will occur. We recommend to low down the working speed under circumstances. Please refer to P1.18 for details.

Allowable Moment

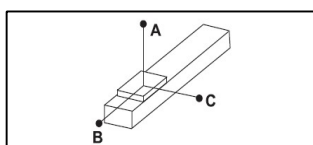

Unit:mm

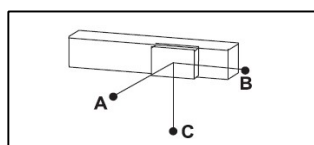

Unit:mm

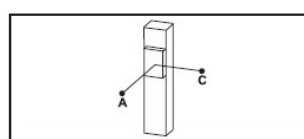

Unit:mm

Static loading moment

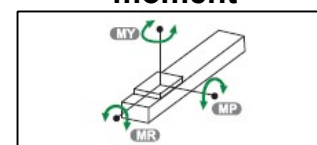

Unit:Nm

Horizontal Installation		A	B	C
5 Lead	60Kg	2850	250	340
	80Kg	2100	180	250
	110K	1500	120	170
10 Lead	30Kg	2850	490	600
	50Kg	1700	280	350
	88Kg	950	140	190
20 Lead	10Kg	3400	1250	1400
	22Kg	1650	550	620
	40Kg	900	290	330
32 Lead	15Kg	1100	570	550
	25Kg	620	330	320
	30Kg	520	270	260

Wall Installation		A	B	C
5 Lead	55Kg	280	280	3300
	75Kg	200	195	2400
	110Kg	130	125	1550
10 Lead	35Kg	400	410	2500
	55Kg	245	250	1550
	88Kg	150	150	950
20 Lead	12Kg	900	1070	3000
	20Kg	550	630	1800
	40Kg	260	300	900
32 Lead	15Kg	440	570	1050
	30Kg	210	270	520
	-	-	-	-

Vertical Installation		A	C
5 Lead	15Kg	1200	1200
	22Kg	820	820
	33Kg	550	550
10 Lead	10Kg	1600	1600
	14Kg	1150	1150
	22Kg	730	730
20 Lead	7Kg	1800	1800
	10Kg	1250	1250
	-	-	-
32 Lead	5Kg	1600	1600
	8Kg	1000	1000
	-	-	-

MY	1168
MP	606
MR	606

Note:

- The torque value in the chart indicates the center of gravity.
- Operation life is 10,000Km when the product is using under the specified conditions.
- Data information is not for ceiling-mount inverse use. Contact us for the details if you want to apply ceiling-mount inverse usage

Linear Electric Actuator

Series AELS

Cat :

Motor Direct - D

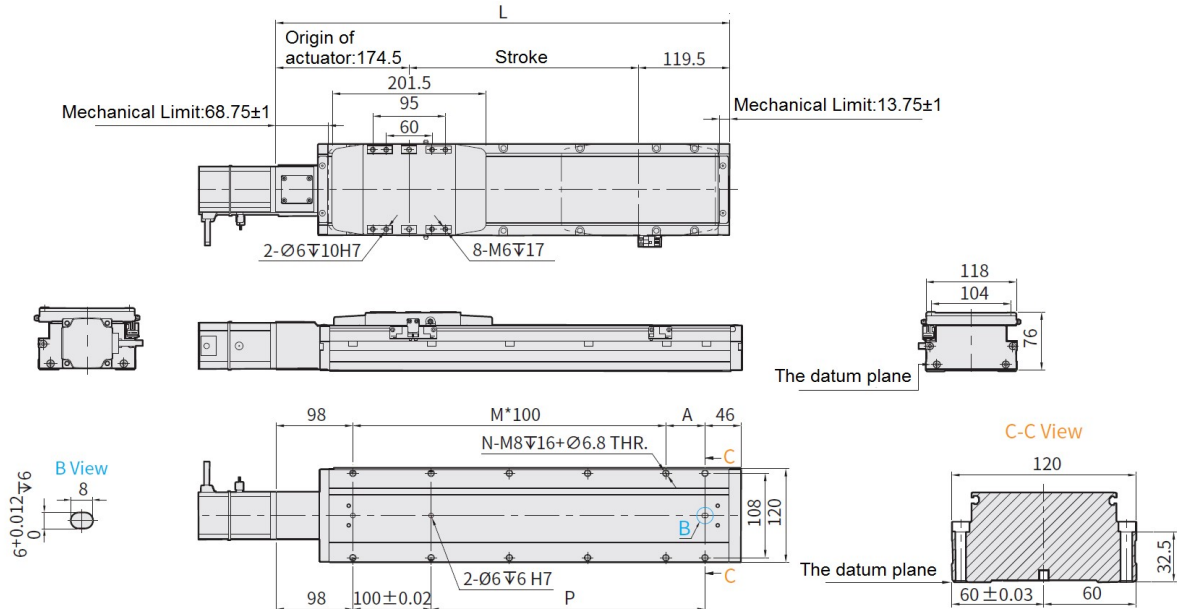

Stroke	50	100	150	200	250	300	350	400	450	500	550	600	650	700	750	800	850	900	950	1000	1050	1100	1150	1200	1250
L	344	394	444	494	544	594	644	694	744	794	844	894	944	994	1044	1094	1144	1194	1244	1294	1344	1394	1444	1494	1544
A	100	50	100	50	100	50	100	50	100	50	100	50	100	50	100	50	100	50	100	50	100	50	100	50	100
M	1	2	2	3	3	4	4	5	5	6	6	7	7	8	8	9	9	10	10	11	11	12	12	13	13
N	6	8	8	10	10	12	12	14	14	16	16	18	18	20	20	22	22	24	24	26	26	28	28	30	30
P	100	150	200	250	300	350	400	450	500	550	600	650	700	750	800	850	900	950	1000	1050	1100	1150	1200	1250	1300
Weight(Kg)	5.05	5.4	5.75	6.1	6.45	6.8	7.15	7.5	7.85	8.2	8.55	8.9	9.25	9.6	9.95	10.3	10.65	11	11.35	11.7	12.05	12.4	12.75	13.1	13.45

Motor Bottom Side - B

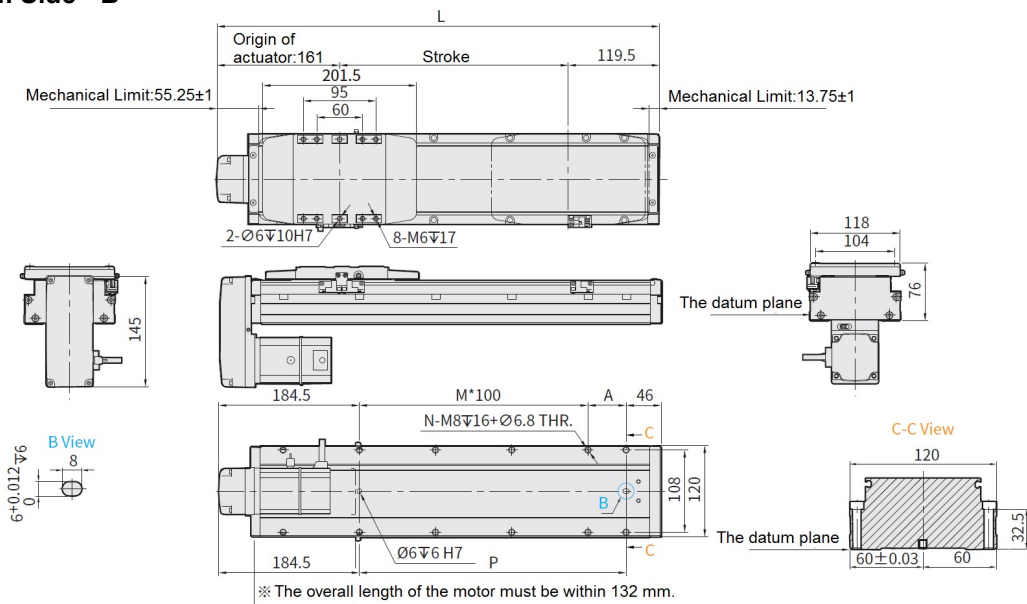

Stroke	50	100	150	200	250	300	350	400	450	500	550	600	650	700	750	800	850	900	950	1000	1050	1100	1150	1200	1250
L	330.5	380.5	430.5	480.5	530.5	580.5	630.5	680.5	730.5	780.5	830.5	880.5	930.5	980.5	1030.5	1080.5	1130.5	1180.5	1230.5	1280.5	1330.5	1380.5	1430.5	1480.5	1530.5
A	100	50	100	50	100	50	100	50	100	50	100	50	100	50	100	50	100	50	100	50	100	50	100	50	100
M	0	1	1	2	2	3	3	4	4	5	5	6	6	7	7	8	8	9	9	10	10	11	11	12	12
N	4	6	6	8	8	10	10	12	12	14	14	16	16	18	18	20	20	22	22	24	24	26	26	28	28
P	100	150	200	250	300	350	400	450	500	550	600	650	700	750	800	850	900	950	1000	1050	1100	1150	1200	1250	1300
Weight(Kg)	5.21	5.56	5.91	6.26	6.61	6.96	7.31	7.66	8.01	8.36	8.71	9.06	9.41	9.76	10.11	10.46	10.81	11.16	11.51	11.86	12.21	12.56	12.91	13.26	13.61

(Note : When motor with brake assembled on lower side, or the total length over than spec limit, it may not use standard pin hole. Please contact us if you need more information.)

Linear Electric Actuator

Series AELS

Cat :

Motor Left Side - L

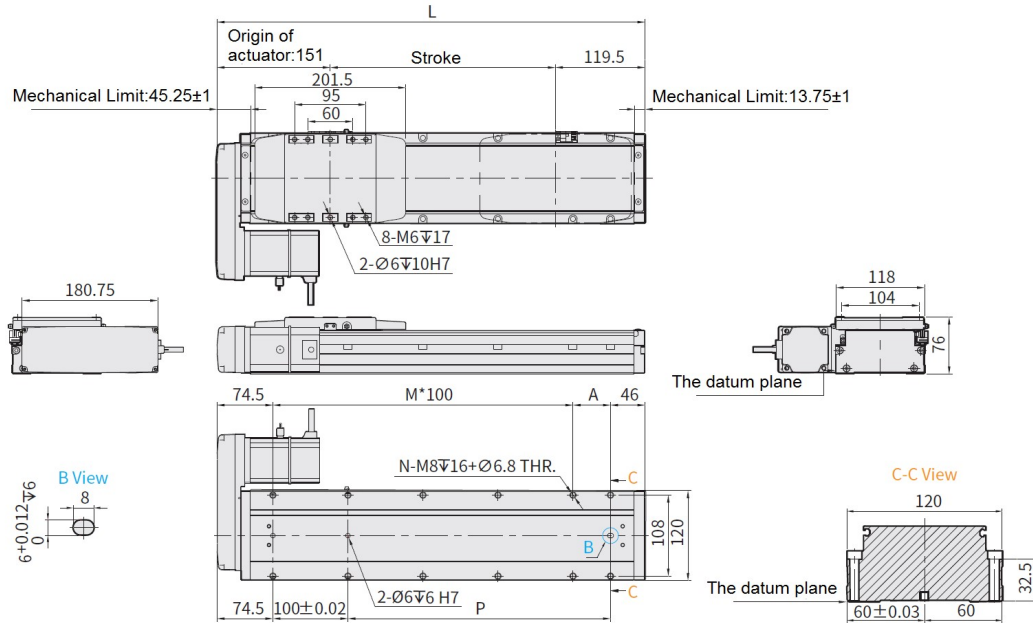

Stroke	50	100	150	200	250	300	350	400	450	500	550	600	650	700	750	800	850	900	950	1000	1050	1100	1150	1200	1250
L	320.5	370.5	420.5	470.5	520.5	570.5	620.5	670.5	720.5	770.5	820.5	870.5	920.5	970.5	1020.5	1070.5	1120.5	1170.5	1220.5	1270.5	1320.5	1370.5	1420.5	1470.5	1520.5
A	100	50	100	50	100	50	100	50	100	50	100	50	100	50	100	50	100	50	100	50	100	50	100	50	100
M	1	2	2	3	3	4	4	5	5	6	6	7	7	8	8	9	9	10	10	11	11	12	12	13	13
N	6	8	8	10	10	12	12	14	14	16	16	18	18	20	20	22	22	24	24	26	26	28	28	30	30
P	100	150	200	250	300	350	400	450	500	550	600	650	700	750	800	850	900	950	1000	1050	1100	1150	1200	1250	1300
Weight(Kg)*	5.25	5.6	5.95	6.3	6.65	7	7.35	7.7	8.05	8.4	8.75	9.1	9.45	9.8	10.15	10.85	11.2	11.55	11.9	12.25	12.6	12.56	12.91	13.26	13.61

Motor Right Side - R

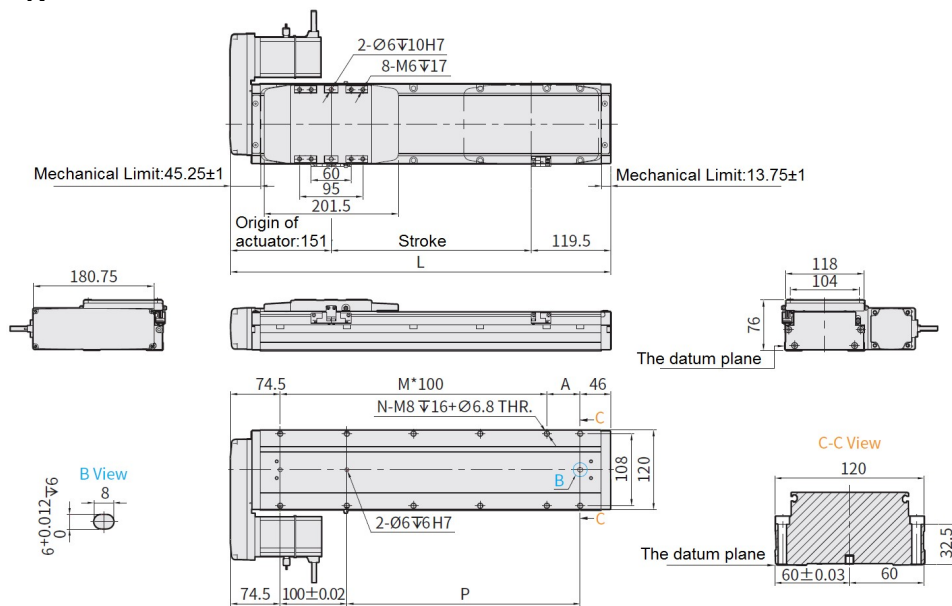

Stroke	50	100	150	200	250	300	350	400	450	500	550	600	650	700	750	800	850	900	950	1000	1050	1100	1150	1200	1250
L	320.5	370.5	420.5	470.5	520.5	570.5	620.5	670.5	720.5	770.5	820.5	870.5	920.5	970.5	1020.5	1070.5	1120.5	1170.5	1220.5	1270.5	1320.5	1370.5	1420.5	1470.5	1520.5
A	100	50	100	50	100	50	100	50	100	50	100	50	100	50	100	50	100	50	100	50	100	50	100	50	100
M	1	2	2	3	3	4	4	5	5	6	6	7	7	8	8	9	9	10	10	11	11	12	12	13	13
N	6	8	8	10	10	12	12	14	14	16	16	18	18	20	20	22	22	24	24	26	26	28	28	30	30
P	100	150	200	250	300	350	400	450	500	550	600	650	700	750	800	850	900	950	1000	1050	1100	1150	1200	1250	1300
Weight(Kg)	5.25	5.6	5.95	6.3	6.65	7	7.35	7.7	8.05	8.4	8.75	9.1	9.45	9.8	10.15	10.85	11.2	11.55	11.9	12.25	12.6	12.56	12.91	13.26	13.61

Linear Electric Actuator

Series AELS

Cat :

How to order

AELS120

Lead	
05	5mm
10	10mm
20	20mm
32	32mm

Stroke	
0050-1200mm	

Motor Position	
D	Direct
L	Left Side
R	Right Side
B	Bottom Side

Motor Specification	
AC Servo	
D	Delta
Y	Yaskawa
M	Mitsubishi
P	Panasonic
V	INVT
T	Others

Motor Power	
AC Servo	
D	400W

Brake	
Nil	Without Brake
B	With Brake

Gear Specification	
Nil	Without Gear Box

Motor & Encoder Cable	
1	1m
3	3m
5	5m
T	10m

I/O Cable	
N	Without Cable
1	1m
A	1.5m
2	2m

Customization Order no	
X	Special Requirements

Example :

Order no. for Rodless type ball screw electric actuator 120mm size, 5mm Lead, 50mm stroke with delta 400W AC servo motor mounted at the motor Direct, With 3m Motor & Encoder cable and 1.5m I/O cable.
AELS120050050D-DD-3A