

# Linear Electric Actuator

## Series AELB

Cat :

### Rod less Electric Actuator-Belt type 135mm

#### Features

- ❑ Compact Robust Design
- ❑ Highly flexible mounting
- ❑ More Precise & positioning
- ❑ Ease of positioning
- ❑ Ease of Maintenance



#### Technical Specifications

Repeatability (mm)		±0.04
Motor Power (AC Servo in W)		200
Lead (mm)		40
Maximum Speed (mm)/s		2000
Maximum Payload	Horizontal (Kg)	25
	Vertical (Kg)	-
Rated Thrust (N)		100
Stroke / Pitch (mm)		50-3050 mm/50mm pitch
Belt width (mm)		22
High Rigidity Linear Guide (mm)		W15XH12.5
Home Sensor	Outside	EE-SX672 (NPN)

\*Acceleration & deceleration value is set as 0.4 seconds

#### Allowable Moment

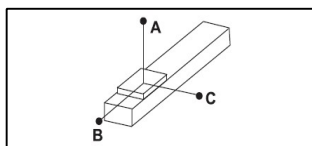

Unit:mm

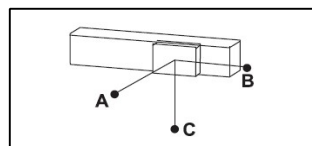

Unit:mm

Horizontal Installation	A	B	C
10Kg	1794	688	538
20Kg	858	324	253
25kg	670	251	197

Wall Installation	A	B	C
15Kg	348	446	1170
18Kg	285	365	961
25kg	197	251	670

#### Static loading moment

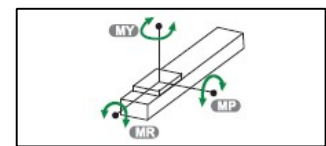

Unit:Nm

MY	551
MP	552
MR	485

**Note:**

- The torque value in the chart indicates the center of gravity.
- Operation life is 10,000km when the product is using under the specified conditions.
- Data information is not for ceiling-mount inverse use. Contact us for the details if you want to apply ceiling- mount inverse usage

# Linear Electric Actuator

## Series AELB

Cat :

### Motor Left side-L

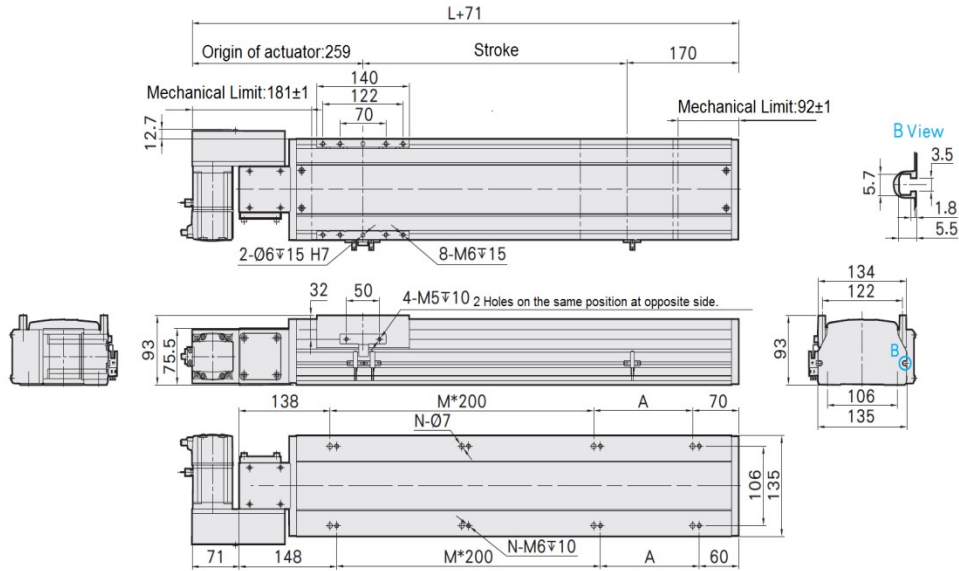

Stroke	50	100	150	200	250	300	350	400	450	500	550	600	650	700	750	800	850	900	950	1000	1050	1100	1150	1200	1250	1300	1350	1400	1450	1500	1550
L	408	458	508	558	608	658	708	758	808	858	908	958	1008	1050	1108	1158	1208	1258	1308	1358	1408	1458	1508	1558	1608	1658	1708	1758	1808	1858	1908
A	200	50	100	150	200	50	100	150	200	50	100	150	200	50	100	150	200	50	100	150	200	50	100	150	200	50	100	150	200	50	100
M	0	1	1	1	1	2	2	2	2	3	3	3	3	4	4	4	4	5	5	5	5	6	6	6	6	7	7	7	7	8	8
N	4	6	6	6	6	8	8	8	8	10	10	10	10	12	12	12	12	14	14	14	14	16	16	16	16	18	18	18	18	20	20
Weight(Kg)*	8.2	8.6	9	9.5	10	10.5	11	11.4	12	12.4	13	13.4	13.9	14.4	14.9	15.4	15.9	16.4	16.9	17.3	17.9	18.5	19.1	19.7	20.3	20.9	21.5	22.1	22.7	23.3	23.9
Stroke	1600	1650	1700	1750	1800	1850	1900	1950	2000	2050	2100	2150	2200	2250	2300	2350	2400	2450	2500	2550	2600	2650	2700	2750	2800	2850	2900	2950	3000	3050	
L	1958	2008	2058	2108	2158	2208	2258	2308	2358	2408	2458	2508	2558	2608	2658	2708	2758	2808	2858	2908	2958	3008	3058	3108	3158	3208	3258	3308	3358	3408	
A	150	200	50	100	150	200	50	100	150	200	50	100	150	200	50	100	150	200	50	100	150	200	50	100	150	200	50	100	150	200	
M	8	8	9	9	9	9	10	10	10	10	11	11	11	11	12	12	12	12	13	13	13	13	14	14	14	14	15	15	15	15	
N	20	20	22	22	22	22	24	24	24	24	26	26	26	26	28	28	28	28	30	30	30	30	32	32	32	32	34	34	34	34	
Weight(Kg)*	24.5	25.1	25.7	26.3	26.9	27.5	28.1	28.7	29.3	29.9	30.5	31.1	31.7	32.3	32.9	33.5	34.1	34.7	35.3	35.9	36.5	37.1	37.7	38.3	38.9	39.5	40.1	40.7	41.3	41.9	

### Motor Right Side-R

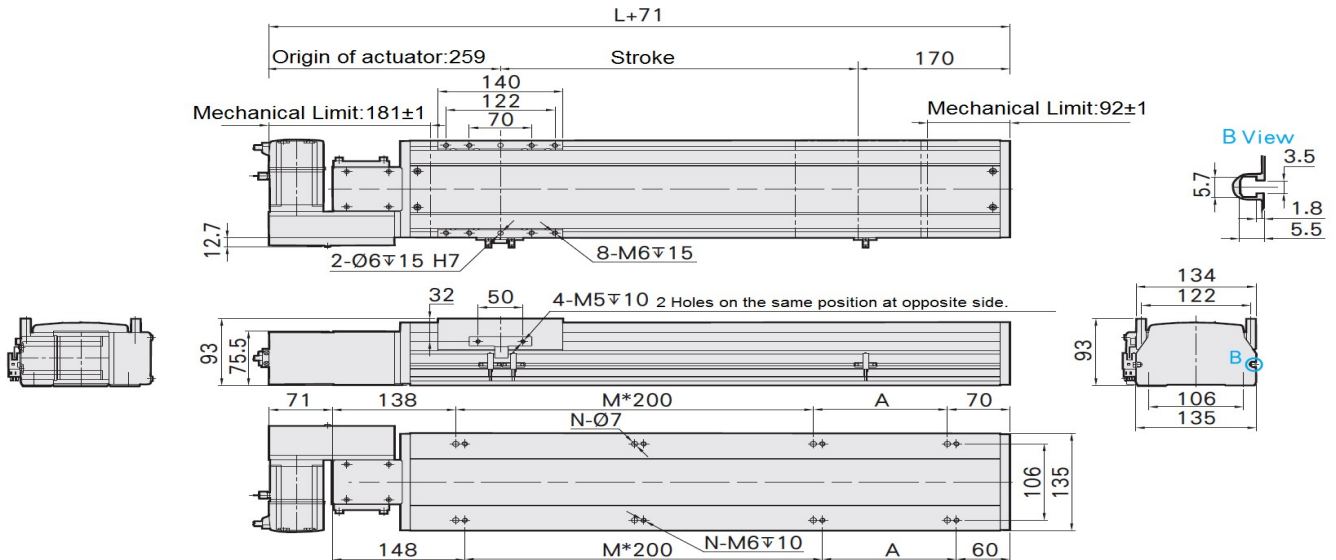

Stroke	50	100	150	200	250	300	350	400	450	500	550	600	650	700	750	800	850	900	950	1000	1050	1100	1150	1200	1250	1300	1350	1400	1450	1500	1550
L	408	458	508	558	608	658	708	758	808	858	908	958	1008	1050	1108	1158	1208	1258	1308	1358	1408	1458	1508	1558	1608	1658	1708	1758	1808	1858	1908
A	200	50	100	150	200	50	100	150	200	50	100	150	200	50	100	150	200	50	100	150	200	50	100	150	200	50	100	150	200	50	100
M	0	1	1	1	1	2	2	2	2	3	3	3	3	4	4	4	4	5	5	5	5	6	6	6	6	7	7	7	7	8	8
N	4	6	6	6	6	8	8	8	8	10	10	10	10	12	12	12	12	14	14	14	14	16	16	16	16	18	18	18	18	20	20
Weight(Kg)*	8.2	8.6	9	9.5	10	10.5	11	11.4	12	12.4	13	13.4	13.9	14.4	14.9	15.4	15.9	16.4	16.9	17.3	17.9	18.5	19.1	19.7	20.3	20.9	21.5	22.1	22.7	23.3	23.9
Stroke	1600	1650	1700	1750	1800	1850	1900	1950	2000	2050	2100	2150	2200	2250	2300	2350	2400	2450	2500	2550	2600	2650	2700	2750	2800	2850	2900	2950	3000	3050	
L	1958	2008	2058	2108	2158	2208	2258	2308	2358	2408	2458	2508	2558	2608	2658	2708	2758	2808	2858	2908	2958	3008	3058	3108	3158	3208	3258	3308	3358	3408	
A	150	200	50	100	150	200	50	100	150	200	50	100	150	200	50	100	150	200	50	100	150	200	50	100	150	200	50	100	150	200	
M	8	8	9	9	9	9	10	10	10	10	11	11	11	11	12	12	12	12	13	13	13	13	14	14	14	14	15	15	15	15	
N	20	20	22	22	22	22	24	24	24	24	26	26	26	26	28	28	28	28	30	30	30	30	32	32	32	32	34	34	34	34	
Weight(Kg)*	24.5	25.1	25.7	26.3	26.9	27.5	28.1	28.7	29.3	29.9	30.5	31.1	31.7	32.3	32.9	33.5	34.1	34.7	35.3	35.9	36.5	37.1	37.7	38.3	38.9	39.5	40.1	40.7	41.3	41.9	

# Linear Electric Actuator

## Series AELB

Cat :

### Motor Left Lower side-Q

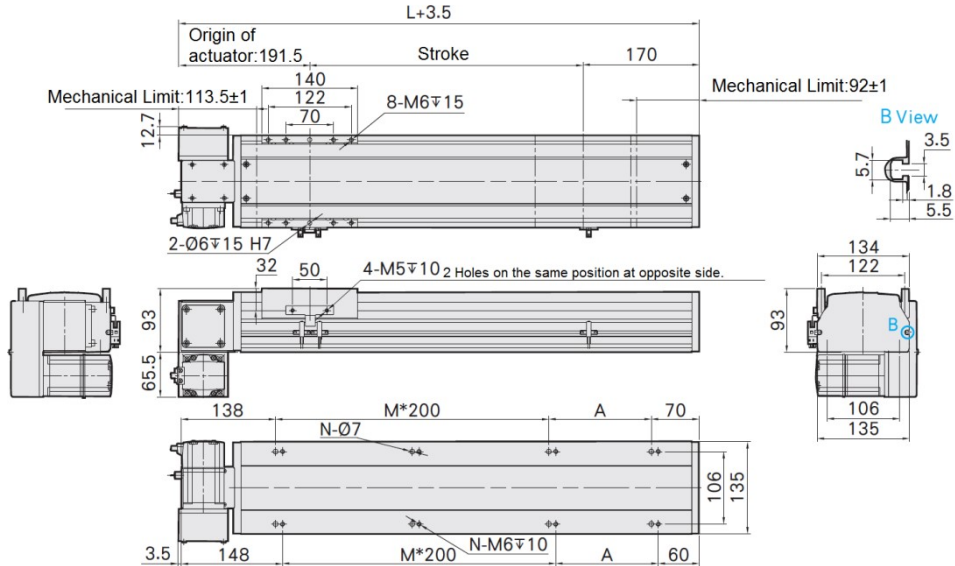

Stroke	50	100	150	200	250	300	350	400	450	500	550	600	650	700	750	800	850	900	950	1000	1050	1100	1150	1200	1250	1300	1350	1400	1450	1500	1550
L	408	458	508	558	608	658	708	758	808	858	908	958	1008	1050	1108	1158	1208	1258	1308	1358	1408	1458	1508	1558	1608	1658	1708	1758	1808	1858	1908
A	200	50	100	150	200	50	100	150	200	50	100	150	200	50	100	150	200	50	100	150	200	50	100	150	200	50	100	150	200	50	100
M	0	1	1	1	1	2	2	2	2	3	3	3	3	4	4	4	4	5	5	5	5	6	6	6	6	7	7	7	7	8	8
N	4	6	6	6	6	8	8	8	8	10	10	10	10	12	12	12	12	14	14	14	14	16	16	16	16	18	18	18	18	20	20
Weight(Kg)*	8.2	8.6	9	9.5	10	10.5	11	11.4	12	12.4	13	13.4	13.9	14.4	14.9	15.4	15.9	16.4	16.9	17.3	17.9	18.5	19.1	19.7	20.3	20.9	21.5	22.1	22.7	23.3	23.9
Stroke	1600	1650	1700	1750	1800	1850	1900	1950	2000	2050	2100	2150	2200	2250	2300	2350	2400	2450	2500	2550	2600	2650	2700	2750	2800	2850	2900	2950	3000	3050	
L	1958	2008	2058	2108	2158	2208	2258	2308	2358	2408	2458	2508	2558	2608	2658	2708	2758	2808	2858	2908	2958	3008	3058	3108	3158	3208	3258	3308	3358	3408	
A	150	200	50	100	150	200	50	100	150	200	50	100	150	200	50	100	150	200	50	100	150	200	50	100	150	200	50	100	150	200	
M	8	8	9	9	9	9	10	10	10	10	11	11	11	11	12	12	12	12	13	13	13	13	14	14	14	14	15	15	15	15	
N	20	20	22	22	22	22	24	24	24	24	26	26	26	26	28	28	28	28	30	30	30	30	32	32	32	32	34	34	34	34	
Weight(Kg)*	24.5	25.1	25.7	26.3	26.9	27.5	28.1	28.7	29.3	29.9	30.5	31.1	31.7	32.3	32.9	33.5	34.1	34.7	35.3	35.9	36.5	37.1	37.7	38.3	38.9	39.5	40.1	40.7	41.3	41.9	

### Motor Right Lower side-Y

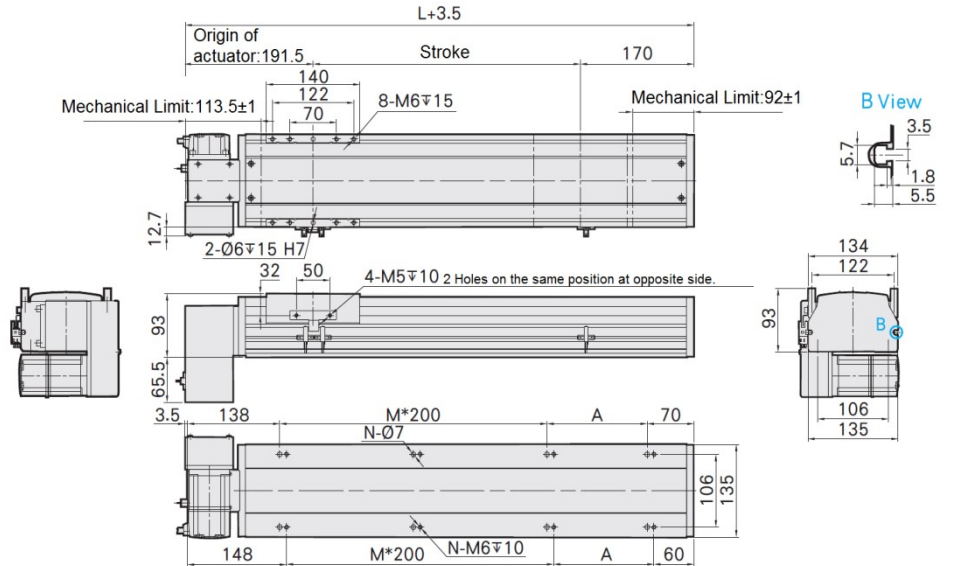

Stroke	50	100	150	200	250	300	350	400	450	500	550	600	650	700	750	800	850	900	950	1000	1050	1100	1150	1200	1250	1300	1350	1400	1450	1500	1550
L	408	458	508	558	608	658	708	758	808	858	908	958	1008	1050	1108	1158	1208	1258	1308	1358	1408	1458	1508	1558	1608	1658	1708	1758	1808	1858	1908
A	200	50	100	150	200	50	100	150	200	50	100	150	200	50	100	150	200	50	100	150	200	50	100	150	200	50	100	150	200	50	100
M	0	1	1	1	1	2	2	2	2	3	3	3	3	4	4	4	4	5	5	5	5	6	6	6	6	7	7	7	7	8	8
N	4	6	6	6	6	8	8	8	8	10	10	10	10	12	12	12	12	14	14	14	14	16	16	16	16	18	18	18	18	20	20
Weight(Kg)*	8.2	8.6	9	9.5	10	10.5	11	11.4	12	12.4	13	13.4	13.9	14.4	14.9	15.4	15.9	16.4	16.9	17.3	17.9	18.5	19.1	19.7	20.3	20.9	21.5	22.1	22.7	23.3	23.9
Stroke	1600	1650	1700	1750	1800	1850	1900	1950	2000	2050	2100	2150	2200	2250	2300	2350	2400	2450	2500	2550	2600	2650	2700	2750	2800	2850	2900	2950	3000	3050	
L	1958	2008	2058	2108	2158	2208	2258	2308	2358	2408	2458	2508	2558	2608	2658	2708	2758	2808	2858	2908	2958	3008	3058	3108	3158	3208	3258	3308	3358	3408	
A	150	200	50	100	150	200	50	100	150	200	50	100	150	200	50	100	150	200	50	100	150	200	50	100	150	200	50	100	150	200	
M	8	8	9	9	9	9	10	10	10	10	11	11	11	11	12	12	12	12	13	13	13	13	14	14	14	14	15	15	15	15	
N	20	20	22	22	22	22	24	24	24	24	26	26	26	26	28	28	28	28	30	30	30	30	32	32	32	32	34	34	34	34	
Weight(Kg)*	24.5	25.1	25.7	26.3	26.9	27.5	28.1	28.7	29.3	29.9	30.5	31.1	31.7	32.3	32.9	33.5	34.1	34.7	35.3	35.9	36.5	37.1	37.7	38.3	38.9	39.5	40.1	40.7	41.3	41.9	

# Linear Electric Actuator

## Series AELB

Cat :

### Motor Left Upper side-P

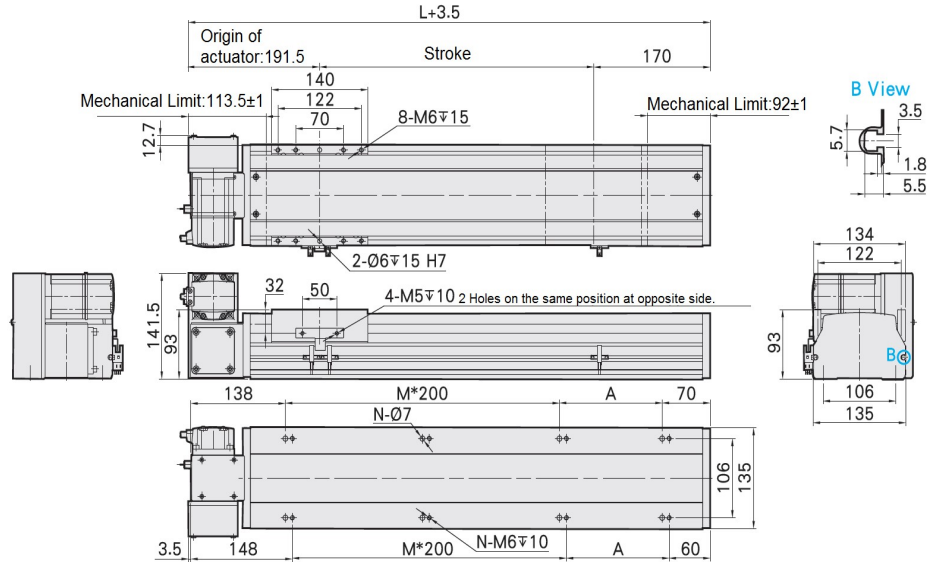

Stroke	50	100	150	200	250	300	350	400	450	500	550	600	650	700	750	800	850	900	950	1000	1050	1100	1150	1200	1250	1300	1350	1400	1450	1500	1550	
L	408	458	508	558	608	658	708	758	808	858	908	958	1008	1050	1108	1158	1208	1258	1308	1358	1408	1458	1508	1558	1608	1658	1708	1758	1808	1858	1908	
A	200	50	100	150	200	50	100	150	200	50	100	150	200	50	100	150	200	50	100	150	200	50	100	150	200	50	100	150	200	50	100	150
M	0	1	1	1	1	2	2	2	2	3	3	3	3	4	4	4	4	5	5	5	5	5	6	6	6	7	7	7	7	8	8	
N	4	6	6	6	6	8	8	8	8	10	10	10	10	12	12	12	12	14	14	14	14	16	16	16	16	18	18	18	18	20	20	
Weight(Kg)*	8.2	8.6	9	9.5	10	10.5	11	11.4	12	12.4	13	13.4	13.9	14.4	14.9	15.4	15.9	16.4	16.9	17.3	17.9	18.5	19.1	19.7	20.3	20.9	21.5	22.1	22.7	23.3	23.9	
Stroke	1600	1650	1700	1750	1800	1850	1900	1950	2000	2050	2100	2150	2200	2250	2300	2350	2400	2450	2500	2550	2600	2650	2700	2750	2800	2850	2900	2950	3000	3050		
L	1958	2008	2058	2108	2158	2208	2258	2308	2358	2408	2458	2508	2558	2608	2658	2708	2758	2808	2858	2908	2958	3008	3058	3108	3158	3208	3258	3308	3358	3408		
A	150	200	50	100	150	200	50	100	150	200	50	100	150	200	50	100	150	200	50	100	150	200	50	100	150	200	50	100	150	200		
M	8	8	9	9	9	9	10	10	10	10	11	11	11	11	12	12	12	12	13	13	13	13	14	14	14	15	15	15	15	15		
N	20	20	22	22	22	22	24	24	24	24	26	26	26	26	28	28	28	28	30	30	30	30	32	32	32	32	34	34	34	34		
Weight(Kg)*	24.5	25.1	25.7	26.3	26.9	27.5	28.1	28.7	29.3	29.9	30.5	31.1	31.7	32.3	32.9	33.5	34.1	34.7	35.3	35.9	36.5	37.1	37.7	38.3	38.9	39.5	40.1	40.7	41.3	41.9		

### Motor Right Upper side-X

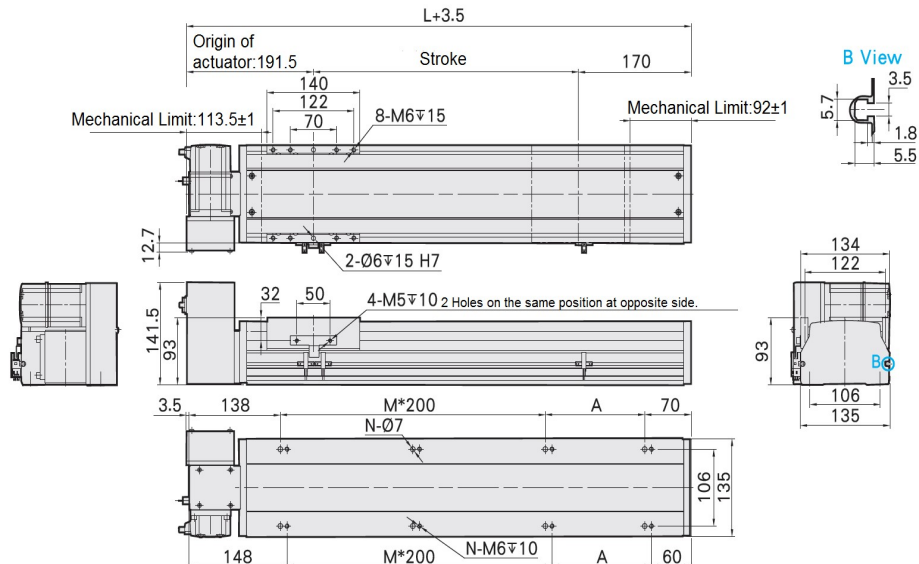











Stroke	50	100	150	200	250	300	350	400	450	500	550	600	650	700	750	800	850	900	950	1000	1050	1100	1150	1200	1250	1300	1350	1400	1450	1500	1550
L	408	458	508	558	608	658	708	758	808	858	908	958	1008	1050	1108	1158	1208	1258	1308	1358	1408	1458	1508	1558	1608	1658	1708	1758	1808	1858	1908
A	200	50	100	150	200	50	100	150	200	50	100	150	200	50	100	150	200	50	100	150	200	50	100	150	200	50	100	150	200	50	100
M	0	1	1	1	1	2	2	2	2	3	3	3	3	4	4	4	4	5	5	5	5	5	6	6	6	7	7	7	7	8	8
N	4	6	6	6	6	8	8	8	8	10	10	10	10	12	12	12	12	14	14	14	14	16	16	16	16	18	18	18	18	20	20
Weight(Kg)*	8.2	8.6	9	9.5	10	10.5	11	11.4	12	12.4	13	13.4	13.9	14.4	14.9	15.4	15.9	16.4	16.9	17.3	17.9	18.5	19.1	19.7	20.3	20.9	21.5	22.1	22.7	23.3	23.9
Stroke	1600	1650	1700	1750	1800	1850	1900	1950	2000	2050	2100	2150	2200	2250	2300	2350	2400	2450	2500	2550	2600	2650	2700	2750	2800	2850	2900	2950	3000	3050	
L	1958	2008	2058	2108	2158	2208	2258	2308	2358	2408	2458	2508	2558	2608	2658	2708	2758	2808	2858	2908	2958	3008	3058	3108	3158	3208	3258	3308	3358	3408	
A	150	200	50	100	150	200	50	100	150	200	50	100	150	200	50	100	150	200	50	100	150	200	50	100	150	200	50	100	150	200	
M	8	8	9	9	9	9	10	10	10	10	11	11	11	11	12	12	12	12	13	13	13	13	14	14	14	15	15	15	15	15	
N	20	20	22	22	22	22	24	24	24	24	26	26	26	26	28	28	28	28	30	30	30	30	32	32	32	32	34	34	34	34	
Weight(Kg)*	24.5	25.1	25.7	26.3	26.9	27.5	28.1	28.7	29.3	29.9	30.5	31.1	31.7	32.3	32.9	33.5	34.1	34.7	35.3	35.9	36.5	37.1	37.7	38.3	38.9	39.5	40.1	40.7	41.3	41.9	

# Linear Electric Actuator

## Series AELB

Cat :

**How to order:**

<b>AELB135</b>	 <table border="1" style="width: 100%; border-collapse: collapse;"> <tr><th colspan="2">Lead</th></tr> <tr><td>40</td><td>40mm</td></tr> </table>	Lead		40	40mm	 <table border="1" style="width: 100%; border-collapse: collapse;"> <tr><th colspan="2">Stroke</th></tr> <tr><td colspan="2">0050-3050mm</td></tr> </table>	Stroke		0050-3050mm		 <table border="1" style="width: 100%; border-collapse: collapse;"> <tr><th colspan="2">Motor Position</th></tr> <tr><td>L</td><td>Left Side</td></tr> <tr><td>R</td><td>Right Side</td></tr> <tr><td>P</td><td>Left Upper</td></tr> <tr><td>Q</td><td>Left Lower</td></tr> <tr><td>X</td><td>Right Upper</td></tr> <tr><td>Y</td><td>Right Lower</td></tr> </table>	Motor Position		L	Left Side	R	Right Side	P	Left Upper	Q	Left Lower	X	Right Upper	Y	Right Lower	 <table border="1" style="width: 100%; border-collapse: collapse;"> <tr><th colspan="2">Motor Specification</th></tr> <tr><th colspan="2">AC Servo</th></tr> <tr><td>D</td><td>Delta</td></tr> <tr><td>Y</td><td>Yaskawa</td></tr> <tr><td>M</td><td>Mitsubishi</td></tr> <tr><td>P</td><td>Panasonic</td></tr> <tr><td>V</td><td>INVT</td></tr> <tr><td>T</td><td>Others</td></tr> </table>	Motor Specification		AC Servo		D	Delta	Y	Yaskawa	M	Mitsubishi	P	Panasonic	V	INVT	T	Others	 <table border="1" style="width: 100%; border-collapse: collapse;"> <tr><th colspan="2">Motor Power</th></tr> <tr><th colspan="2">AC Servo</th></tr> <tr><td>C</td><td>200W</td></tr> </table>	Motor Power		AC Servo		C	200W
Lead																																																	
40	40mm																																																
Stroke																																																	
0050-3050mm																																																	
Motor Position																																																	
L	Left Side																																																
R	Right Side																																																
P	Left Upper																																																
Q	Left Lower																																																
X	Right Upper																																																
Y	Right Lower																																																
Motor Specification																																																	
AC Servo																																																	
D	Delta																																																
Y	Yaskawa																																																
M	Mitsubishi																																																
P	Panasonic																																																
V	INVT																																																
T	Others																																																
Motor Power																																																	
AC Servo																																																	
C	200W																																																
	 <table border="1" style="width: 100%; border-collapse: collapse;"> <tr><th colspan="2">Brake</th></tr> <tr><td>Nil</td><td>Without Brake</td></tr> <tr><td>B</td><td>With Brake</td></tr> </table>	Brake		Nil	Without Brake	B	With Brake	 <table border="1" style="width: 100%; border-collapse: collapse;"> <tr><th colspan="2">Gear Specification</th></tr> <tr><td>Nil</td><td>Without Gear Box</td></tr> </table>	Gear Specification		Nil	Without Gear Box	 <table border="1" style="width: 100%; border-collapse: collapse;"> <tr><th colspan="2">Motor &amp; Encoder Cable</th></tr> <tr><td>1</td><td>1m</td></tr> <tr><td>3</td><td>3m</td></tr> <tr><td>5</td><td>5m</td></tr> <tr><td>T</td><td>10m</td></tr> </table>	Motor & Encoder Cable		1	1m	3	3m	5	5m	T	10m	 <table border="1" style="width: 100%; border-collapse: collapse;"> <tr><th colspan="2">I/O Cable</th></tr> <tr><td>N</td><td>Without Cable</td></tr> <tr><td>1</td><td>1m</td></tr> <tr><td>A</td><td>1.5m</td></tr> <tr><td>2</td><td>2m</td></tr> </table>	I/O Cable		N	Without Cable	1	1m	A	1.5m	2	2m	 <table border="1" style="width: 100%; border-collapse: collapse;"> <tr><th colspan="2">Customization Order no</th></tr> <tr><td>X</td><td>Special Requirements</td></tr> </table>	Customization Order no		X	Special Requirements										
Brake																																																	
Nil	Without Brake																																																
B	With Brake																																																
Gear Specification																																																	
Nil	Without Gear Box																																																
Motor & Encoder Cable																																																	
1	1m																																																
3	3m																																																
5	5m																																																
T	10m																																																
I/O Cable																																																	
N	Without Cable																																																
1	1m																																																
A	1.5m																																																
2	2m																																																
Customization Order no																																																	
X	Special Requirements																																																

**Example :**

Ordering no. for Rodless electric actuator-Belt type 135mm size,40mm belt lead,150 mm stroke with Delta 200W servo motor mounted at the left side, with 3m Motor cable,1.5m I/O cable.

**AELB135400150L-DC-3A**