

# Linear Electric Actuator

## Series AELB

Cat :

### Rod less Electric Actuator-Belt type 50mm

#### Features

- Compact Robust Design
- Highly flexible mounting
- More Precise & positioning
- Ease of positioning
- Ease of Maintenance



#### Technical Specifications

Repeatability (mm)		±0.04
Motor Power (AC Servo in W)		100
Lead (mm)		40
Maximum Speed (mm)/s		2000
Maximum Payload	Horizontal (Kg)	3
	Vertical (Kg)	-
Rated Thrust (N)		42
Stroke / Pitch (mm)		50-800 mm/50mm pitch
Belt width (mm)		9
High Rigidity Linear Guide (mm)		W24XH8.5
Home Sensor	Outside	EE-SX672 (NPN)

\*Acceleration & deceleration value is set as 0.4 seconds

#### Allowable Moment

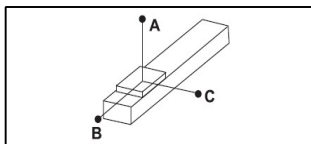

Unit:mm

Horizontal Installation	A	B	C
2Kg	323	61	112
3Kg	209	39	72

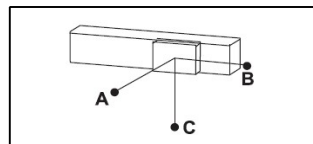

Unit:mm

Wall Installation	A	B	C
2Kg	105	57	303
3Kg	67	36	195

#### Static loading moment

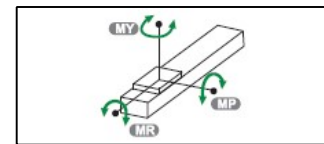

Unit:Nm

MY	16
MP	20
MR	19

#### Note:

- The torque value in the chart indicates the center of gravity.
- Operation life is 5000Km when the product is using under the specified conditions.
- Data information is not for ceiling-mount inverse use. Contact us for the details if you want to apply ceiling- mount inverse usage

# Linear Electric Actuator

## Series AELB

Cat :

### Motor Bottom side-B

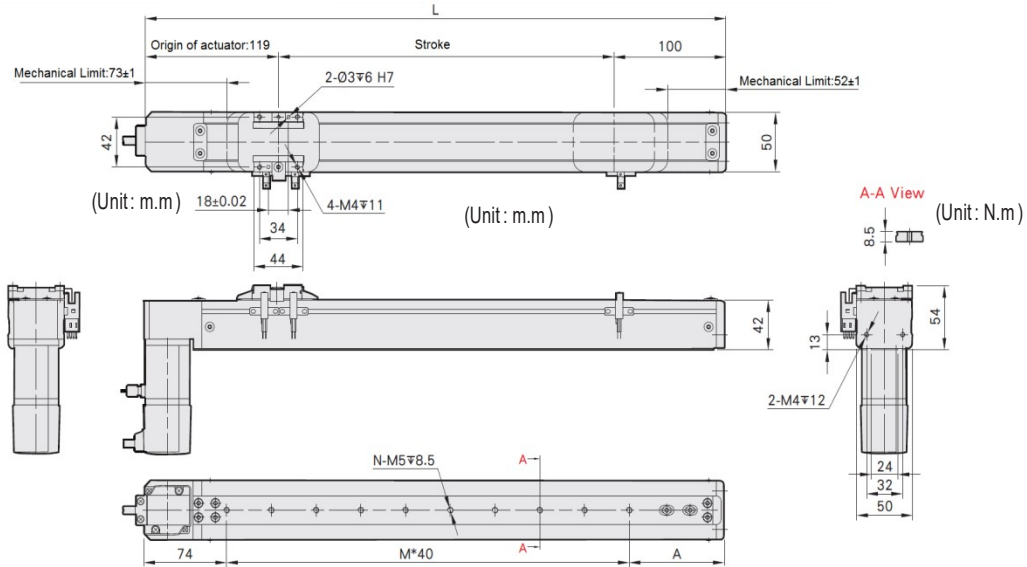

Stroke	50	100	150	200	250	300	350	400	450	500	550	600	650	700	750	800
L	269	319	369	419	469	519	569	619	669	719	769	819	869	919	969	1019
A	75	85	95	65	75	85	95	65	75	85	95	65	75	85	95	65
M	3	4	5	7	8	9	10	12	13	14	15	17	18	19	20	22
N	4	5	6	8	9	10	11	13	14	15	16	18	19	20	21	23
Weight (Kg)*	2.1	2.2	2.3	2.4	2.5	2.6	2.7	2.8	2.9	3	3.1	3.2	3.3	3.4	3.5	3.6

### Motor Top side-T

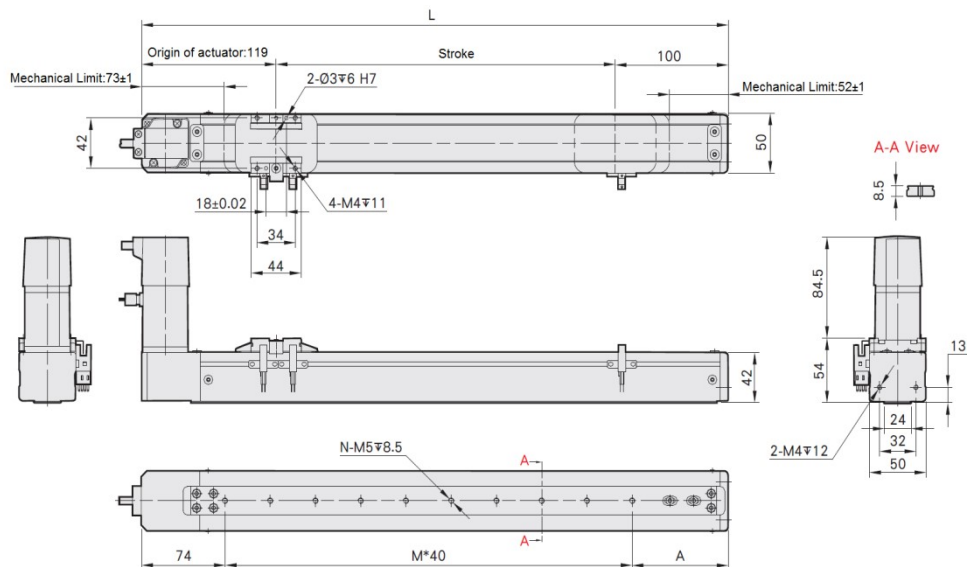

Stroke	50	100	150	200	250	300	350	400	450	500	550	600	650	700	750	800
L	269	319	369	419	469	519	569	619	669	719	769	819	869	919	969	1019
A	75	85	95	65	75	85	95	65	75	85	95	65	75	85	95	65
M	3	4	5	7	8	9	10	12	13	14	15	17	18	19	20	22
N	4	5	6	8	9	10	11	13	14	15	16	18	19	20	21	23
Weight(Kg)*	2.1	2.2	2.3	2.4	2.5	2.6	2.7	2.8	2.9	3	3.1	3.2	3.3	3.4	3.5	3.6

# Linear Electric Actuator

## Series AELB

Cat :

### How to order

**AELB050**

Lead	
32	32mm
40	40mm

Stroke	
0050-0800mm	

Motor Position	
T	Top Side
B	Bottom Side

Motor Specification	
AC Servo	
D	Delta
Y	Yaskawa
M	Mitsubishi
P	Panasonic
V	INVT
T	Others

Motor Power	
AC Servo	
B	100W

Brake	
Nil	Without Brake
B	With Brake

Gear Specification	
Nil	Without Gear Box

Motor & Encoder Cable	
1	1m
3	3m
5	5m
T	10m

I/O Cable	
N	Without Cable
1	1m
A	1.5m
2	2m

Customization Order no	
X	Special Requirements

### Example :

Ordering no. for Rodless electric actuator-Belt type 50mm size,32mm belt lead,150 mm stroke with Delta 100W Servo motor mounted at the bottom side, with 3m Motor cable,1.5m I/O cable.

**AELB050320150B-DB-3A**